

GUARDIAN LIFT TABLES

"U" and "E" Shaped Low Profile Lift Tables 3 1/4" Lowered Height

The "U" and "E" Low Profile Tables have all the safety features of our Low Profile Guardian Series Lift Tables. The low profile feature provides greater flexibility since a variety of applications can be accommodated. Also, installation costs are reduced since the need for a floor pit is eliminated.

With capacities ranging from 2,200 pounds to 3,300 pounds, the Guardian Series low profile lift tables are available with either an "E" or "U" shaped top for numerous material handling applications.

The "U" shaped low profile table is ideal for handling wire baskets, containers, plastic and wooden open bottom pallets. This design allows loading with either a manual or electric pallet truck without the need for a loading ramp.

The E-Lift low profile lift table has all the same features as the U-Lift and the other Guardian low profile tables. It is available in a 2,200 lb capacity. The advantage of the E-Lift is the center opening measures 28.9" which is ideal for a standard 27" wide pallet truck. The added center support of the E-Lift is designed to help prevent the pallet from deflecting downward in the center due to the wider center area. The center support is shorter than the outside legs to allow easier access with the pallet truck. The E-Lift, like the U-Lift, is designed for use with open bottom pallets, skids, containers or wire baskets.

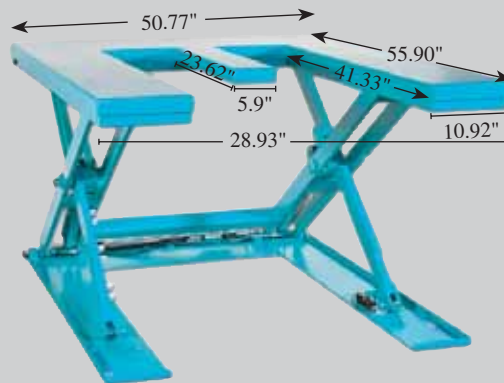

"U" Shaped Lifts

VERTICAL TRAVEL	MODEL	CAPACITY (LBS.)	PLATFORM SIZE	BASE FRAME	LOWERED HEIGHT	RAISED HEIGHT	LIFT SPEED (SECONDS)	MOTOR (HP)
30 3/4	LPBLU-20-1	2,200	44 7/8 X 56*	42 X 52	3 1/8	33 7/8	18	1
29 1/2	LPBLU-30-1	3,300	45 5/8 X 59 7/8*	43 X 56 1/4	3 5/8	33 1/8	25	1

"E" Shaped Lifts

VERTICAL TRAVEL	MODEL	CAPACITY (LBS.)	PLATFORM SIZE	BASE FRAME	LOWERED HEIGHT	RAISED HEIGHT	LIFT SPEED (SECONDS)	MOTOR (HP)
30 3/4	LPBLE -20-1	2,200	55 7/8 X 50	54 X 52	3 1/8	33 7/8	18	1